

Safe – Low Particle Content – Standard Sizes

Tub and Nest

Added Value Total **Solution** Provider for Your
Pharmaceutical Packaging Product.

Low particle content from production to application

The tubs and nests go through a fully automated extraction and packaging process:

- Removal of parts from the mold
- Filing of parts and formation of stacks
- Packaging of stacks including labeling

All process steps take place under cleanroom conditions.

Economic Efficiency

- Significant reduction of TCO
- No investments in tools and other equipment

Flexibility

- Standard items with short delivery times
- Compatible with common assembly and filling lines

Quality

- Established raw materials (PS and PP)
- Suitable for common sterilization methods
- Dimensionally stable
- Enables sterile filling of syringes
- With over 20 years of expertise
- Globally leading reference customers
- Swiss quality and trust worthiness

Application

The tubs and nests are suitable for the following prefillable syringes:

- Nest 100 PP Ø 12.2 (10x10) for 0.5 ml, 1.0 ml long and 1.0 - 3.0 ml
- Nest 160 PP Ø 9.4 (10x16) for 0.5 ml and 1.0 ml long

Certification

- GMP Class C and ISO 7
- ISO 13485
- ISO 11040-7
- Institute of Environmental Sciences and Technology's standard IEST-STD-CC1246 (level 200)



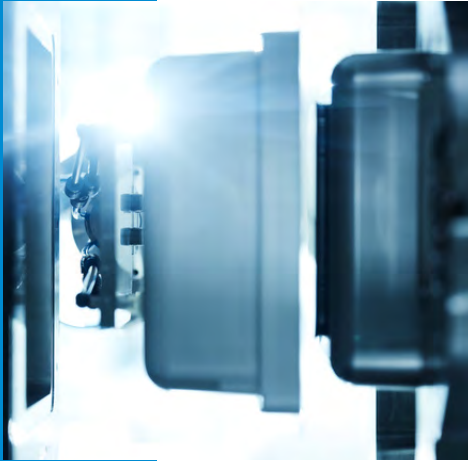

Tub 96

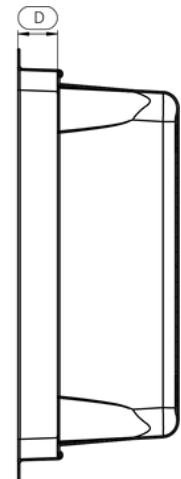
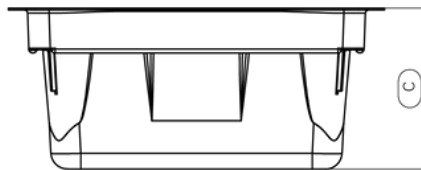
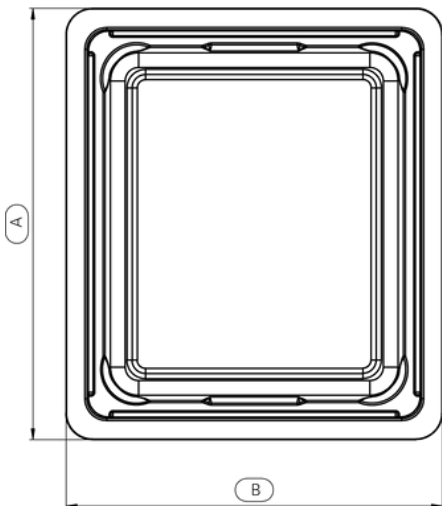

Technical Specifications

Item number	Description	Color	Pieces per pallet	Dimensions in mm				Material type
				A	B	C	D	
0170091	Tub 96	white	792	260	227	97	24	PS
0170095	Tub 96	transparent	792	260	227	97	24	SBC & SMMA

Standard quantity per pallet

- Disposable pallet 120 x 80 cm
- Standard height approx. 225 cm



Nest

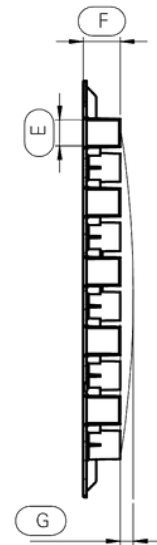

Nest 100 Ø 12.2 mm

Nest 160 Ø 9.4 mm

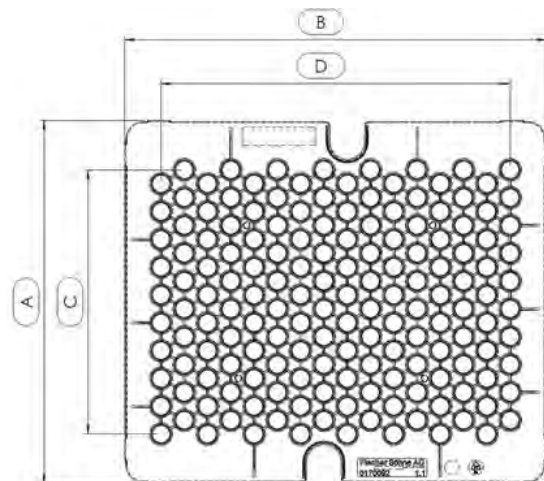
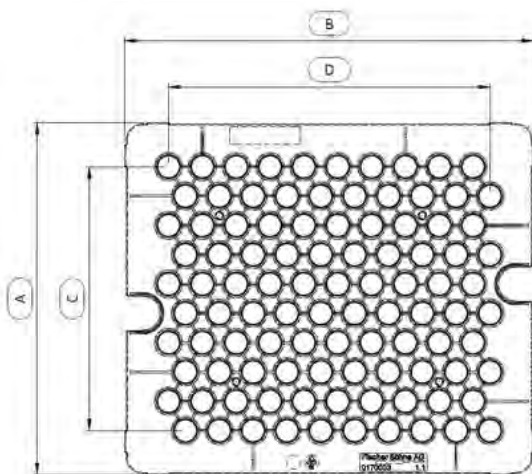

Technical Specifications

Item number	Description	Color	Pieces per pallet	Dimensions in mm							Material type
				A	B	C	D	E	F	G deflection	
0170053	Nest 100 Ø 12.2 mm	natur	1800	198.5	230.2	148.5	180.9	12.2	17.5	max. 1.5	PP
0170092	Nest 160 Ø 9.4 mm	natur	1800	198.5	230.2	144.4	190.5	9.4	17.5	max. 1.5	PP

Standard quantity per pallet

- Disposable pallet 120 x 80 cm
- Standard height approx. 225 cm





Contact

Fischer Söhne AG



Fischer Söhne AG
Luzernerstrasse 105
5630 Muri AG
Switzerland



www.fischersoehne.ch



[/fischersoehneag](https://www.linkedin.com/company/fischersoehneag)



+41 56 675 49 00



verkauf@fischersoehne.ch

